

RoHS Compliant

SATA-Disk Module 4

SDM4-M 7P/180D Low Profile Specifications

August 28th, 2012

Version 1.3



Apacer Technology Inc.

4th Fl., 75 Hsin Tai Wu Rd., Sec.1, Hsichih, New Taipei City, Taiwan 221

Tel: +886-2-2698-2888 Fax: +886-2-2698-2889

www.apacer.com

Features:

- **Standard Serial ATA 2.6 (Gen. 2)**
 - Serial ATA 2.6 (Gen. 2)
 - SATA II, 3.0 Gbps
 - ATA-compatible command set
- **Capacities**
 - 4, 8, 16, 32 GB
- **Performance***
 - Burst read/write: 300 MB/sec
 - Sustained read: up to 43 MB/sec
 - Sustained write: up to 21 MB/sec
- **Intelligent endurance design**
 - Built-in hardware ECC, enabling up to 16/24 bit correction per 1K bytes
 - Static wear-leveling scheme together with dynamical block allocation to significantly increase the lifetime of a flash device and optimize the disk performance
 - Flash bad-block management
 - S.M.A.R.T.
 - Power Failure Management
 - ATA Secure Erase
 - TRIM
- **NAND Flash Type: MLC**
- **MTBF: >1,000,000 hours**
- **Zero power data retention**
 - No battery required for data storage
- **Temperature ranges**
 - Operation:
 - Standard: 0°C to 70°C
 - Extended: -40 ~ +85°C *****
 - Storage: -40°C to 100°C
- **Supply voltage**
 - 5.0 V \pm 5%
- **Power consumption (typical)***
 - Active mode: 185 mA@5.0 V
 - Idle mode: 85 mA@5.0 V
- **Connector type**
 - 7-pin signal connector
 - Option : 2-pin additional power connector
- **Form factor**
 - SATA Disk Module
 - Dimension (w/o housing): 30.00x20.00x1.00**, unit: mm
 - Dimension (w/ housing): 32.50x23.30x8.53**, unit: mm
- **Shock & Vibration******
 - Shock: 1500 G
 - Vibration: 15 G
- **RoHS compliant**

*Varies from capacities. The values for performances and power consumptions presented are typical and may vary depending on flash configurations or platform settings. The term idle refers to the standby state of the device.

**Without including the size of SATA connector

***Only available in 4, 8, 16GB capacities. Please see "Product Ordering Information" for details.

****Non-operating

Table of Contents

1. GENERAL DESCRIPTION	3
1.1 PERFORMANCE-OPTIMIZED CONTROLLER	3
1.1.1 Power Management Unit (PMU).....	3
1.1.2 SRAM Buffer.....	3
2. FUNCTIONAL BLOCK	4
3. PIN ASSIGNMENTS	5
4. PRODUCT SPECIFICATION	7
4.1 CAPACITY	7
4.2 ATA MODES SUPPORT	7
4.3 PERFORMANCE	7
4.4 ENVIRONMENTAL SPECIFICATIONS	8
4.5 MEAN TIME BETWEEN FAILURES (MTBF)	8
4.6 CERTIFICATION AND COMPLIANCE	8
5. FLASH MANAGEMENT	9
5.1 ERROR CORRECTION/DETECTION	9
5.2 BAD BLOCK MANAGEMENT	9
5.3 WEAR LEVELING	9
5.4 POWER FAILURE MANAGEMENT.....	9
5.5 ATA SECURE ERASE	9
5.6 S.M.A.R.T.....	10
5.7 TRIM	10
6. SOFTWARE INTERFACE	11
6.1 COMMAND SET	11
7. ELECTRICAL SPECIFICATION	12
8. PHYSICAL CHARACTERISTICS	13
8.1 POWER CABLE TYPE.....	13
8.1.1 W/o Housing	13
8.1.2 W/ Housing.....	14
8.2 POWER CABLE-LESS TYPE	15
8.2.1 W/o Housing.....	15
8.2.2 W/ Housing.....	16
9. PRODUCT ORDERING INFORMATION	17
9.1 PRODUCT CODE DESIGNATIONS	17

1. General Description

Apacer's SATA-Disk Module 4-M (SDM4-M) is a high-performance, embedded SSD designed to replace the conventional SATA hard disk drive. SDM SSD can be plugged into a standard Serial ATA connectors commonly found in desktops, IT-STB, industrial PC and thin client systems. Though built with MLC, this SSD can work in highly demanding environment as it can withstand ambient temperature from -40°C to +85°C (for certain capacities only).

Apacer's SDM4-M is built in with an efficient microcontroller that drives the potential of NAND flashy and delivers optimal performance. With its compact form factor and SATA II interface, this product is well suited for embedded flash storage applications offering customizable and expanded functionalities as well as more cost-effective designs, better performance and increased reliability.

SDM4-M Series is designed to work at 5 Volts and uses a standard SATA driver that complies with major operating systems such as Microsoft's Windows series. Featuring technologies as Apacer-specific Wear-leveling algorithms, S.M.A.R.T, Enhanced Data Integrity, Intelligent Power Failure Management, ATA Secure Erase, and TRIM, Apacer assures users of a versatile device on data storage.

1.1 Performance-Optimized Controller

The heart of SDM4-M is the Flash controller, which translates standard SATA signals into the data and controls of the flash media. The SATA and Flash Management controller are specifically designed to attain high data throughput from the host to the flash.

1.1.1 Power Management Unit (PMU)

The power management unit (PMU) controls the power consumption of SDM4-M. It can dramatically extend product battery life by leaving the idle part of the circuitry into sleep mode. The PMU has zero wake-up latency.

1.1.2 SRAM Buffer

The Flash Controller performs as a SRAM buffer to optimize the host's data transfer to and from the flash media.

2. Functional Block

SDM4-M includes the SATA and Flash Management controllers, and flash media, as well as the SATA standard interface. Figure 2-1 shows the functional block diagram.

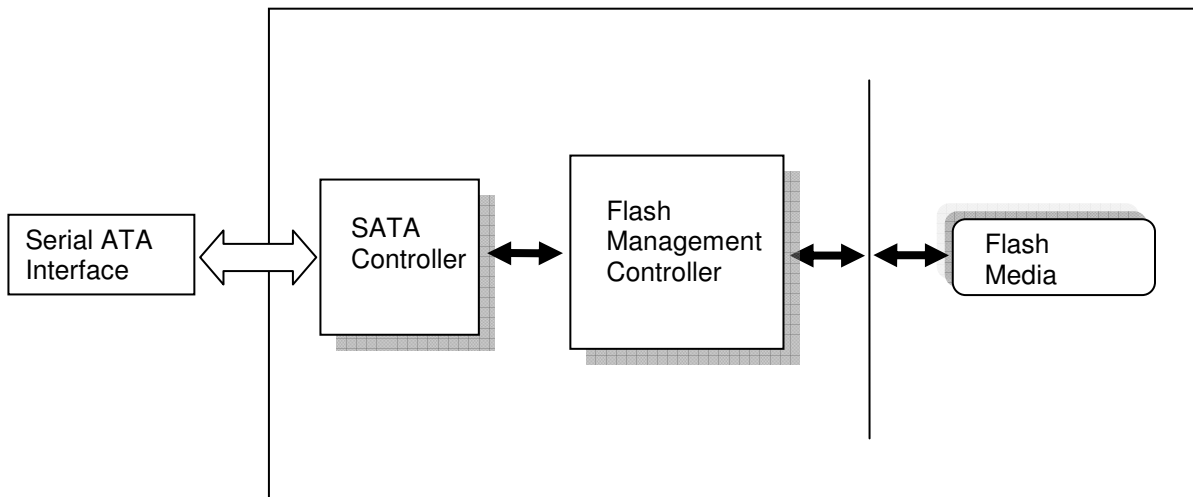
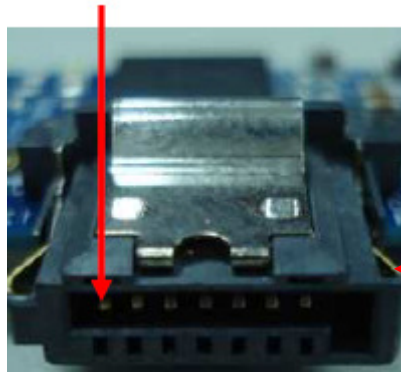

Figure 2-1: Functional block diagram

3. Pin Assignments

Signal Pin 1



Power Pin1

Power cable type w/o housing

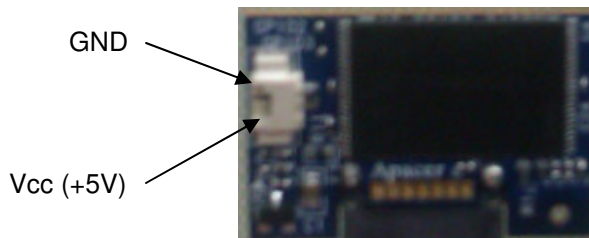

Power cable type w/ housing

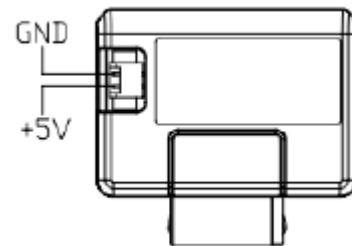

Signal Segment

Pin	Type	Signal Description
S1	GND	
S2	RxP	+Differential Receive Signal
S3	RxN	-Differential Receive Signal
S4	GND	
S5	TxN	-Differential Transmit Signal
S6	TxP	+Differential Transmit Signal
S7	GND	

Power Segment

Pin	Signal Description
P1	Vcc (+5V)
P2	GND

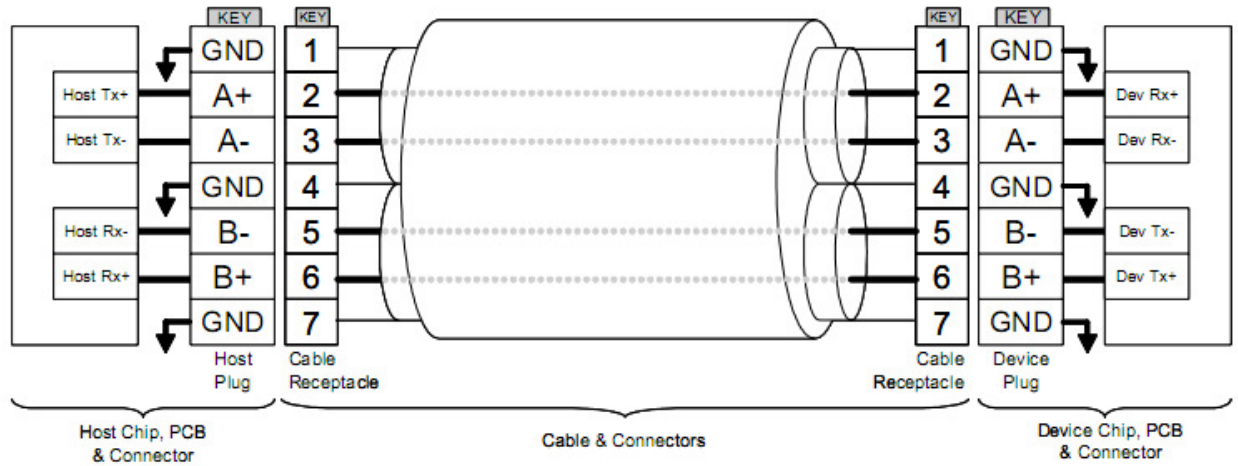

Figure 3-1: SATA Cable/Connector Connection Diagram

The connector on the left represents the Host with TX/RX differential pairs connected to a cable. The connector on the right shows the Device with TX/RX differential pairs also connected to the cable. Notice also the ground path connecting the shielding of the cable to the Cable Receptacle.

4. Product Specification

4.1 Capacity

Capacity specification of SDM4-M product family is available as shown in Table 4-1. It lists the specific capacity and the default numbers of heads, sectors and cylinders for each product line.

Table 4-1: Capacity specifications

Capacity	Total bytes*	Cylinders	Heads	Sectors	Max LBA
4 GB	4,011,614,208	7,773	16	63	7,835,184
8 GB	8,012,390,400	15,525	16	63	15,649,200
16 GB	16,013,942,784	16,383	16	63	31,277,232
32 GB	32,017,047,552	16,383	16	63	62,533,296

*Display of total bytes varies from file systems.

LBA count addressed in the table above indicates total user storage capacity and will remain the same throughout the lifespan of the device. However, the total usable capacity of the SSD is most likely to be less than the total physical capacity because a small portion of the capacity is reserved for device maintenance usages.

4.2 ATA Modes Support

SDM4-M supports the following ATA operating modes:

- Supports up to PIO Mode-4
- Supports up to Multi-word DMA Mode-2
- Supports up to Ultra DMA Mode-5

4.3 Performance

Performances of SDM4-M are listed below in table 4-2.

Table 4-2: Performance (Typical)

Capacity	4 GB	8 GB	16 GB	32 GB
Performance				
Sustained read (MB/s)	34	38	40	43
Sustained write (MB/s)	6	11	19	21

Note: Results may differ from various flash configurations or host system settings.

4.4 Environmental Specifications

Environmental specification of SDM4 product family which follows the MIL-STD-202 and our test standard is indicated in Table 4-3.

Table 4-3 SDM4 environmental specifications

Item	Specification
Operating temperature	0~70(°C)
Extended temperature	-40 ~ +85(°C)
Storage temperature	-40~100(°C)
Vibration (non-operating)	10~2000(Hz), 15(G), sine wave, X, Y, Z axis
Vibration (operating)	20~2000(Hz), 7.69 (Grms), random wave, X, Y, Z axis
Shock (non-operating)	1500(G) half-sine wave, ±X, ±Y, ±Z axis
Shock (operating)	50(G), half sine wave, ±X, ±Y, ±Z axis

Note: extended operating temperature specifications are only available for 4, 8, 16GB capacities.

4.5 Mean Time Between Failures (MTBF)

Mean Time Between Failures (MTBF) is predicted based on reliability data for the individual components in SDM4-M. The prediction result for SDM4-M is more than 1,000,000 hours.

Notes about the MTBF:

The MTBF is predicated and calculated based on “Telcordia Technologies Special Report, SR-332, Issue 2” method.

4.6 Certification and Compliance

SDM4-M complies with the following standards:

- CE – EN55022/55024
- FCC 47CFR Part15 Class B
- RoHS
- MIL-STD-202 and MIL-STD-810
- SATA II (SATA Rev. 2.6)
- Up to ATA/ATAPI-7 (including S.M.A.R.T.)

5. Flash Management

5.1 Error Correction/Detection

SDM4-M implements a hardware ECC scheme, based on the BCH algorithm. It can detect and correct up to 16 bits or 24 bits error in 1K bytes.

5.2 Bad Block Management

Contemporary process technology is unable to guarantee total reliability of NAND flash memory array. When a flash memory device leaves factory, it comes with a highly minimal number of initial bad block during production or out-of-factory as there is no currently known technology that produce flash chips free of bad blocks. On the other hand, bad blocks may develop during program/erase cycles. When host performs program/erase command on a block, bad block may appear in Status Register. Since bad blocks are inevitable, the solution is to keep them in control. Apacer flash devices are programmed with ECC, block mapping technique and S.M.A.R.T to reduce invalidity or error. Once bad blocks are detected, data in those blocks will be transferred to free blocks and error will be corrected by designated algorithms.

5.3 Wear Leveling

Flash memory devices differ from Hard Disk Drives (HDDs) in terms of how blocks are utilized. For HDDs, when a change is made to stored data, like erase or update, the controller mechanism on HDDs will perform overwrites on blocks. On the other hand, NAND flash storage adopts flash as their primary media. Unlike HDDs, flash blocks cannot be overwritten and each P/E cycle wears down the lifespan of blocks gradually. Repeatedly program/erase cycles performed on the same memory cells will eventually cause some blocks to age faster than others. This would bring flash storages to their end of service term earlier. Wear leveling is an important mechanism that level out the wearing of blocks so that the wearing-down of blocks can be almost evenly distributed. This will increase the lifespan of SSDs. Commonly used wear leveling types are Static and Dynamic.

5.4 Power Failure Management

Power Failure Management ensures data transmission when experiencing unstable power supply. When power disruption takes places, NAND Flash will have to cache multiple write-to-flash cycles to securely store data. This urgent operation requires about several milliseconds to get it done. When the supplied voltage is below a certain percentage of the required, the flash controller will be signaled by a detector IC component with low power detection signal and then the firmware will communicate the controller to flush all the data into the cache of Flash storage area. This can prevent incomplete data transmission. The crucial part lies in the strength of the capacitor of the SSD. The capacitor must be able to hold up some milliseconds of remaining time before the power is totally out, for the urgent write-back-into-flash operations to complete.

5.5 ATA Secure Erase

Accomplished by the Secure Erase (SE) command, which is added to the open ANSI standards that control disk drives, "ATA Secure Erase" is built into the disk drive itself and thus far less susceptible to malicious software attacks than external software utilities. It is an easy-to-use data destroy command, amounting to electronic data shredding. Executing the command causes a drive to internally completely erase all possible user data. This command is carried out within disk drives, so no additional software is

required. Once executed, neither data nor the erase counter on the device would be recoverable, which blurs the accuracy of device lifespan. The process to erase will not be stopped until finished even if power failure is encountered, and will be continued when power resumes.

5.6 S.M.A.R.T.

S.M.A.R.T. is an acronym for Self-Monitoring, Analysis and Reporting Technology, an open standard allowing disk drives to automatically monitor their own health and report potential problems. It protects the user from unscheduled downtime by monitoring and storing critical drive performance and calibration parameters. Ideally, this should allow taking proactive actions to prevent impending drive failure.

Apacer devices use the standard SMART command B0h to read data out from the drive to activate our S.M.A.R.T. feature that complies with the ATA/ATAPI-7 specifications. Based on the SFF-8035i Rev. 2.0 specifications, S.M.A.R.T. Attribute IDs shall include initial bad block count, bad block count, spare block count, maximum erase count, average erase count and power cycle. When the S.M.A.R.T. Utility running on the host, it analyzes and reports the disk status to the host before the device reaches in critical condition.

5.7 TRIM

Made of millions of NAND flash cells, SSD can be written into groups called pages in 4K size generally, but can only be erased in larger groups called blocks of 128 pages or 512KB. These stipulations are partially the source of many performance issues. Until an address gets used again, the SSD has to keep track of every last bit of data that's written on it. The ATA-TRIM instruction tilts the balance in favor of the SSD. TRIM addresses a major part of the performance degradation issue over time that plagues all SSDs. A TRIM enabled drive running an OS with TRIM support will stay closer to its peak performance over time.

6. Software Interface

6.1 Command Set

This section defines the software requirements and the format of the commands the host sends to SDM4-M. Commands are issued to SDM4-M by loading the required registers in the command block with the supplied parameters, and then writing the command code to the Command register.

Table 6-1: Command set

Code	Command	Code	Command
E5h	Check Power Mode	F3h	Security Erase Prepare
06h	Data Set Management	F4h	Security Erase Unit
90h	Execute Device Diagnostic	F5h	Security Freeze Lock
E7h	Flush Cache	F1h	Security Set Password
EAh	Flush Cache EXT	F2h	Security Unlock
ECh	Identify Device	70h	Seek
E3h	Idle	EFh	Set Features
E1h	Idle Immediate	C6h	Set Multiple Mode
91h	Initialize Device Parameters	E6h	Sleep
C8h	Read DMA	B0h	SMART
25h	Read DMA EXT	E2h	Standby
C4h	Read Multiple	E0h	Standby Immediate
29h	Read Multiple EXT	CAh	Write DMA
20h	Read Sector	35h	Write DMA EXT
24h	Read Sector EXT	C5h	Write Multiple
40h	Read Verify Sectors	39h	Write Multiple EXT
42h	Read Verify Sectors EXT	30h	Write Sector
10h	Recalibrate	34h	Write Sector EXT
F6h	Security Disable Password		

7. Electrical Specification

Caution: Absolute Maximum Stress Ratings – Applied conditions greater than those listed under “Absolute Maximum Stress Ratings” may cause permanent damage to the device. This is a stress rating only and functional operation of the device at these conditions or conditions greater than those defined in the operational sections of this data sheet is not implied. Exposure to absolute maximum stress rating conditions may affect device reliability.

Table 7-1: Operating range

Range	Ambient Temperature	5V
Standard	0 °C to +70 °C	4.75-5.25V
Extended Temperature	-40 °C to 85 °C	

Note: extended temperature is only available for 4, 8, 16GB capacities of this product family.

Table 7-2: Power consumption (typical)

Capacity	4 GB	8 GB	16 GB	32 GB
Modes				
Active (mA)	165	165	185	185
Idle (mA)	85	85	85	85

Note: Results may differ from various flash configurations or platforms.

8. Physical Characteristics

8.1 Power Cable Type

7-pin/180 Degree Low Profile Module

8.1.1 W/o Housing

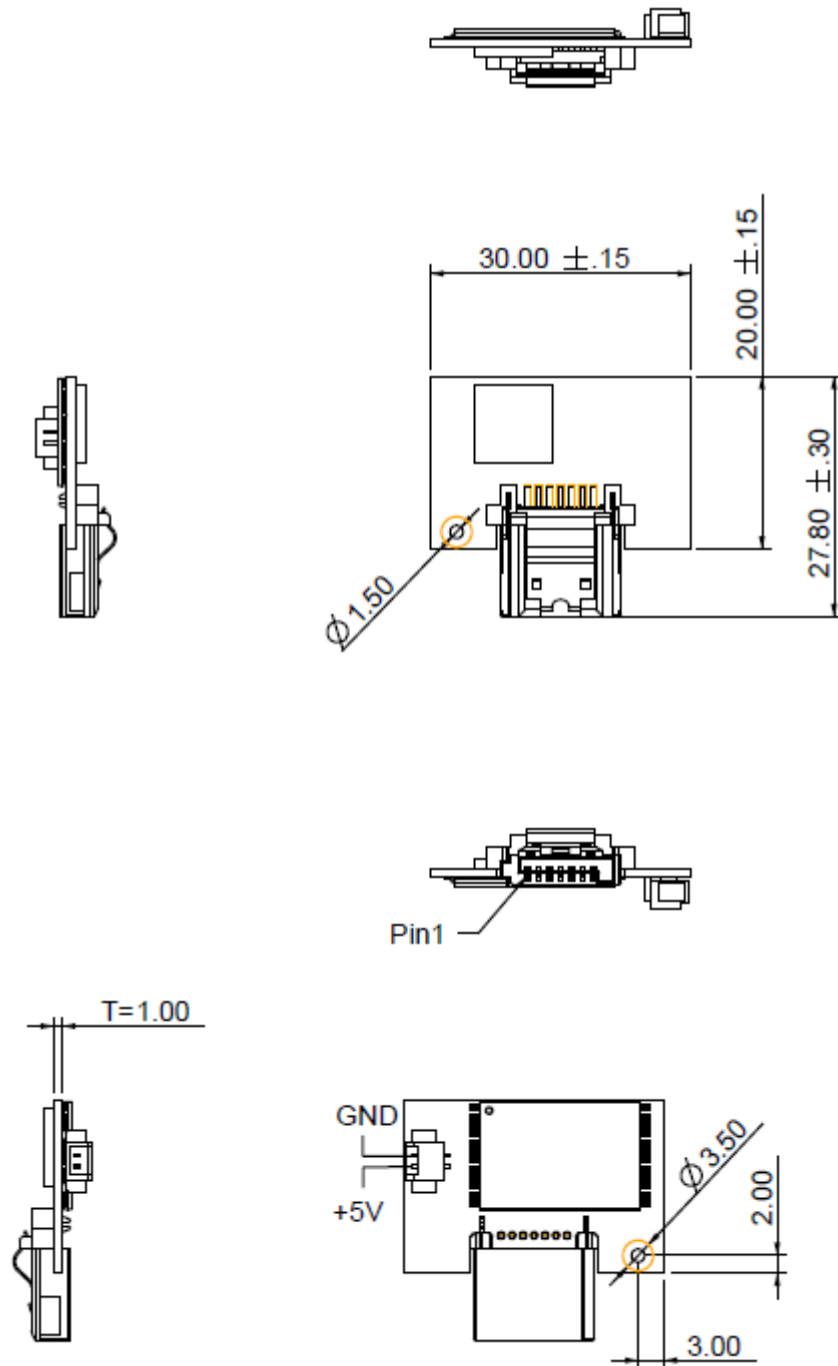

Unit: mm
 Tolerance: ± 0.25

SATA-Disk Module 4 APSDMxxxxX5AN-CCMXX

8.1.2 W/ Housing

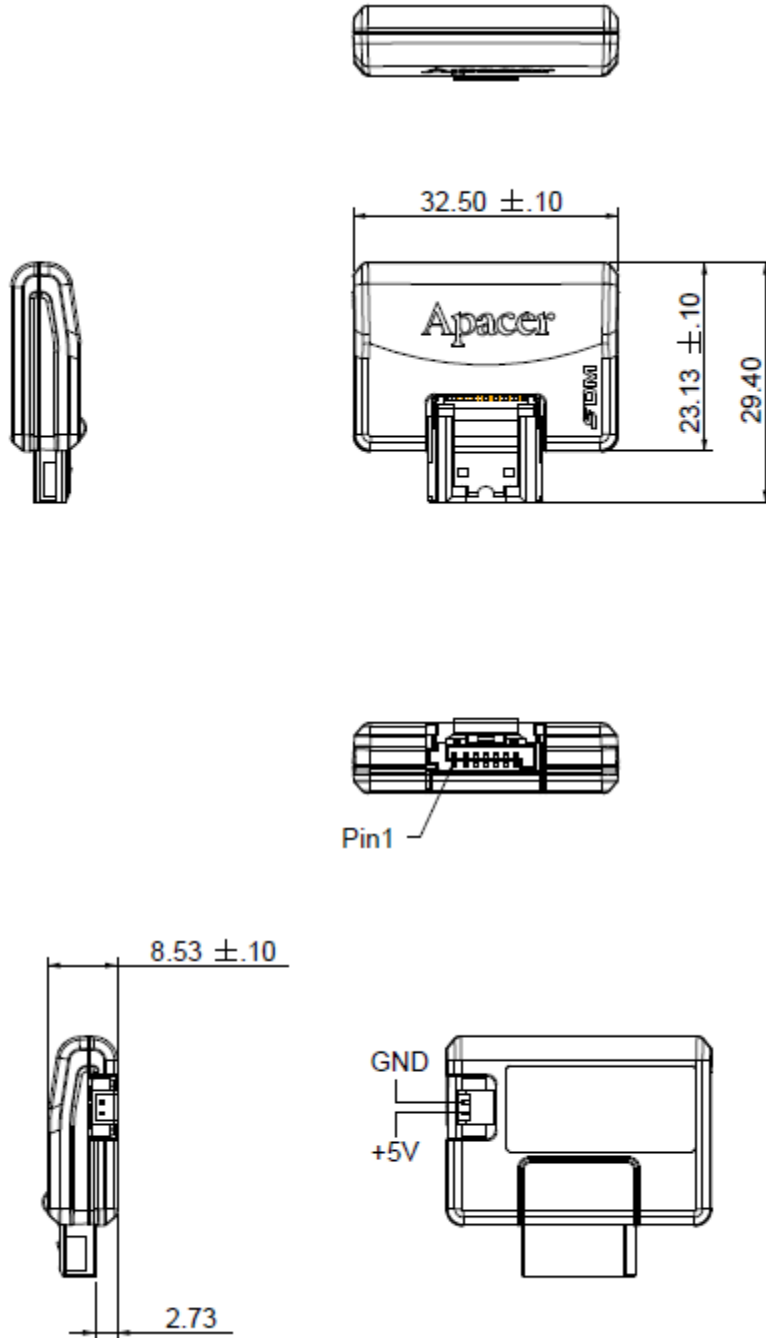

Unit: mm
Tolerance: ± 0.25

8.2 Power Cable-less Type

7-pin/180 Degree Low Profile Module

8.2.1 W/o Housing

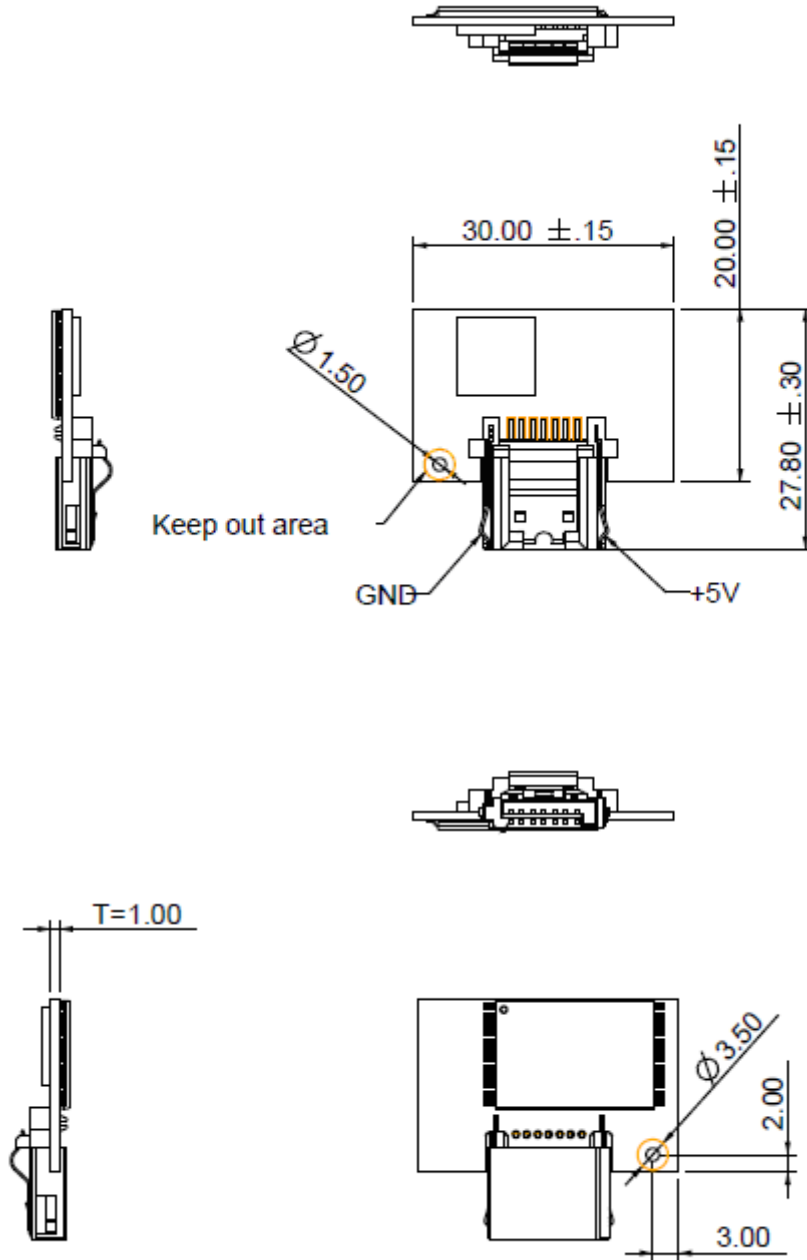

Unit: mm
Tolerance: ± 0.25

SATA-Disk Module 4 APSDMxxxxX5AN-CCMXX

8.2.2 W/ Housing

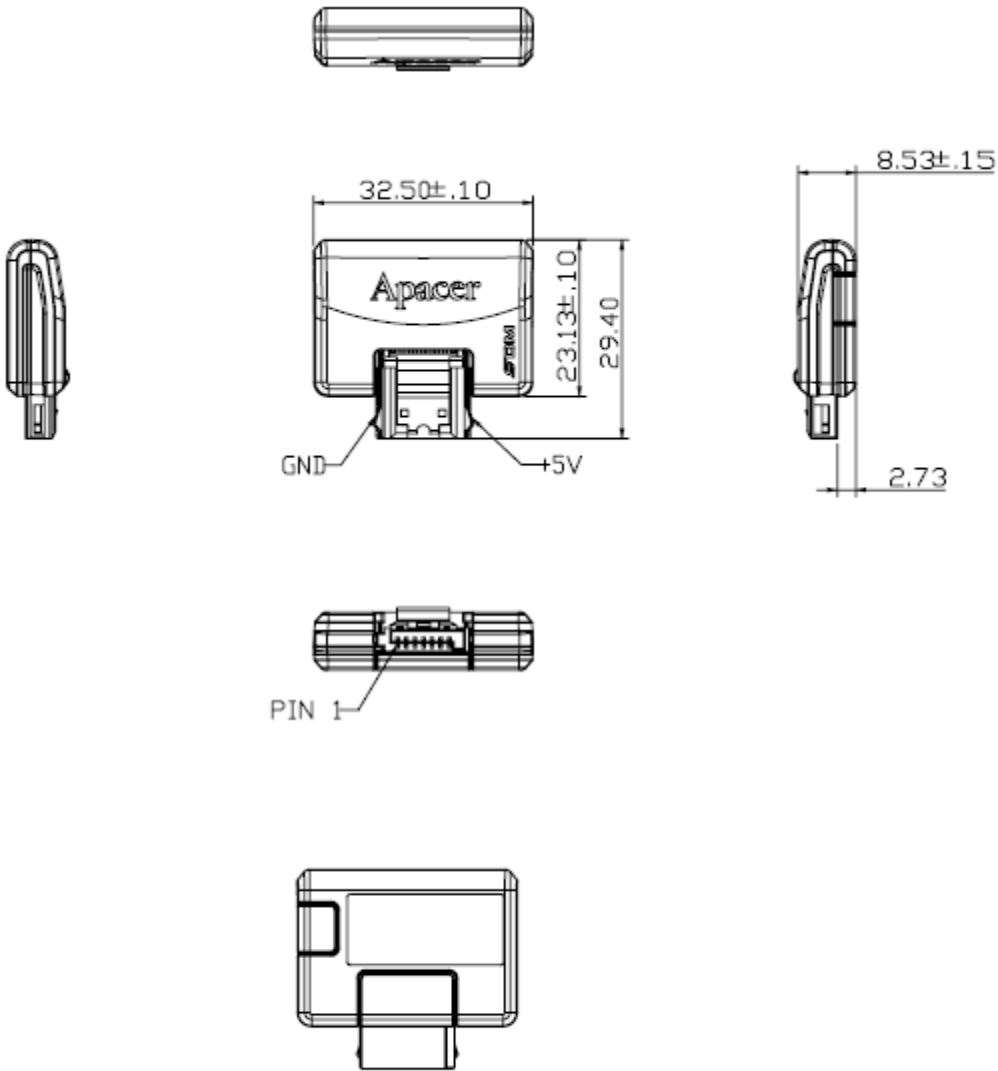

Unit: mm
Tolerance: ± 0.25

9. Product Ordering Information

9.1 Product Code Designations

A P SDM x x x x X 5 AN - C C M X X

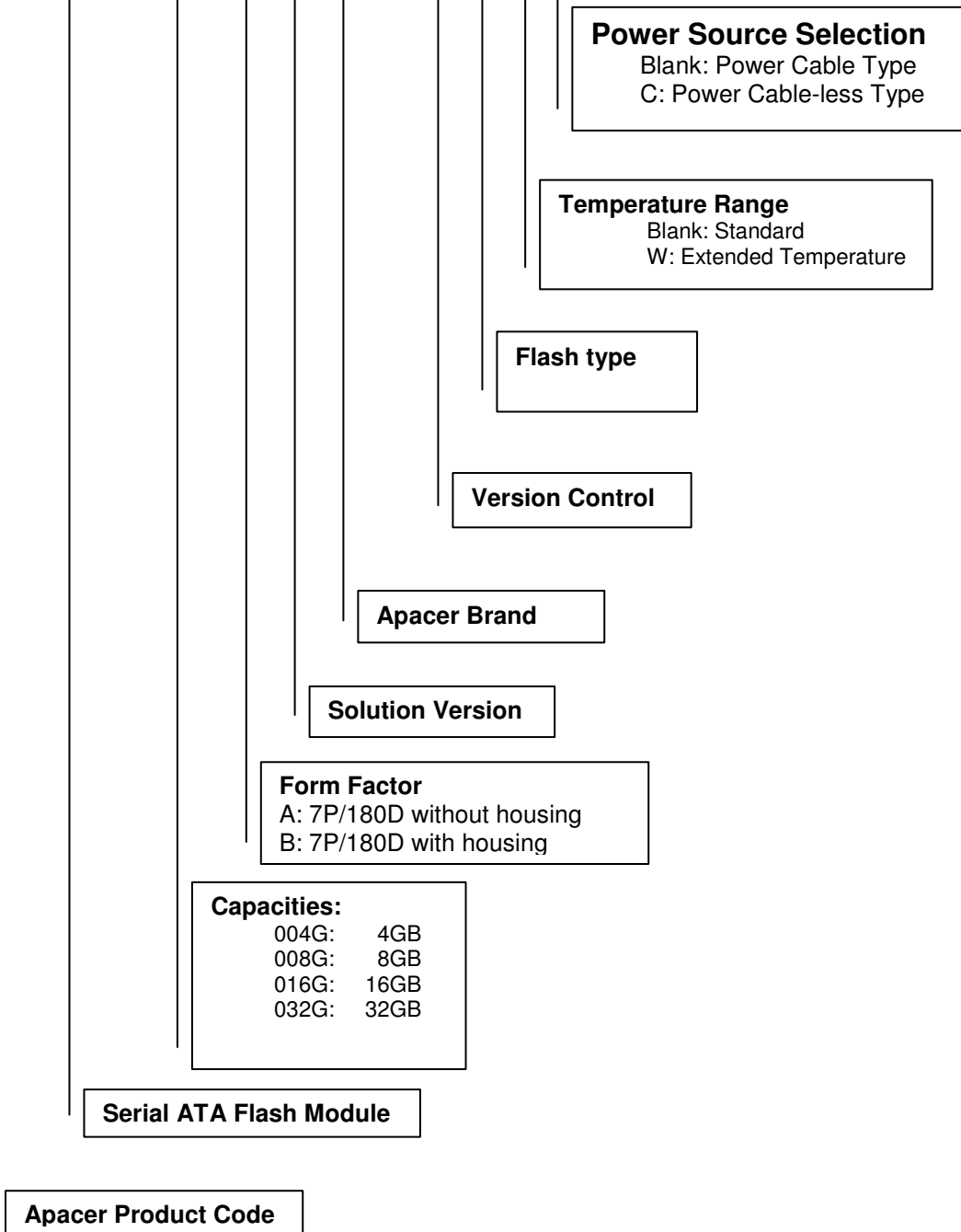

9.2 Valid Combinations

7P/180D LP without housing: Power Cable Type

Capacity	Standard	Extended Temperature
4GB	APSDM004GA5AN-CCM	APSDM004GA5AN-CCMW
8GB	APSDM008GA5AN-CCM	APSDM008GA5AN-CCMW
16GB	APSDM016GA5AN-CCM	APSDM016GA5AN-CCMW
32GB	APSDM032GA5AN-CCM	--

7P/180D LP with housing: Power Cable Type

Capacity	Standard	Extended Temperature
4GB	APSDM004GB5AN-CCM	APSDM004GB5AN-CCMW
8GB	APSDM008GB5AN-CCM	APSDM008GB5AN-CCMW
16GB	APSDM016GB5AN-CCM	APSDM016GB5AN-CCMW
32GB	APSDM032GB5AN-CCM	--

7P/180D LP without housing: Power Cable-less Type

Capacity	Standard	Extended Temperature
4GB	APSDM004GA5AN-CCMC	APSDM004GA5AN-CCMWC
8GB	APSDM008GA5AN-CCMC	APSDM008GA5AN-CCMWC
16GB	APSDM016GA5AN-CCMC	APSDM016GA5AN-CCMWC
32GB	APSDM032GA5AN-CCMC	--

7P/180D LP with housing: Power Cable-less Type

Capacity	Standard	Extended Temperature
4GB	APSDM004GB5AN-CCMC	APSDM004GB5AN-CCMWC
8GB	APSDM008GB5AN-CCMC	APSDM008GB5AN-CCMWC
16GB	APSDM016GB5AN-CCMC	APSDM016GB5AN-CCMWC
32GB	APSDM032GB5AN-CCMC	--

Note: Please consult with Apacer sales representatives for availabilities.

Revision History

Revision	Date	Description	Remark
1.0	02/22/2012	Official release	
1.1	03/12/2012	Updated Product Ordering Information Added "Housing" to physical design	
1.2	04/06/2012	Updated mechanical drawings Updated S.M.A.R.T. information Updated Product Ordering Information	
1.3	08/28/2012	Updated Product Ordering Information due to firmware upgrade	

Global Presence

Taiwan (Headquarters)	Apacer Technology Inc. 4 th Fl., 75 Hsin Tai Wu Rd., Sec.1 Hsichih, New Taipei City Taiwan 221 R.O.C. Tel: +886-2-2698-2888 Fax: +886-2-2698-2889 amtsales@apacer.com
U.S.A.	Apacer Memory America, Inc. 386 Fairview Way, Suite102, Milpitas, CA 95035 Tel: 1-408-518-8699 Fax: 1-408-935-9611 sa@apacerus.com
Japan	Apacer Technology Corp. 5F, Matsura Bldg., Shiba, Minato-Ku Tokyo, 105-0014, Japan Tel: 81-3-5419-2668 Fax: 81-3-5419-0018 jpservices@apacer.com
Europe	Apacer Technology B.V. Science Park Eindhoven 5051 5692 EB Son, The Netherlands Tel: 31-40-267-0000 Fax: 31-40-267-0000#6199 sales@apacer.nl
China	Apacer Electronic (Shanghai) Co., Ltd 1301, No.251,Xiaomuqiao Road, Shanghai, 200032, China Tel: 86-21-5529-0222 Fax: 86-21-5206-6939 sales@apacer.com.cn
India	Apacer Technologies Pvt Ltd, # 535, 1st Floor, 8th cross, JP Nagar 3rd Phase, Bangalore – 560078, India Tel: 91-80-4152-9061 sales_india@apacer.com