

RoHS Recast Compliant

ATA Disk Module 5S-M

ADM5S-M 44P/180D Middle Profile Product Specifications
(Toshiba 15nm)

January 11, 2016

Version 1.0



Apacer Technology Inc.

1F, No.32, Zhongcheng Rd., Tucheng Dist., New Taipei City, Taiwan, R.O.C

Tel: +886-2-2267-8000 Fax: +886-2-2267-2261

www.apacer.com

Features:

- **Standard ATA/IDE Bus Interface**
 - ATA command set compatible
 - Compliant with ATA/ATAPI-8
 - ATA operating mode supports up to:
 - PIO Mode up to 4
 - Multiword DMA Mode up to 2
 - Ultra DMA Mode up to 6
- **Connector Type**
 - 44-pin female connector (2.00mm pitch)
- **Power Consumption***
 - Supply voltage: 3.3V & 5V
 - Active mode: 250 mA
 - Idle mode: 170 mA
- **Performance***
 - Sustained read: Up to 100 MB/sec
 - Sustained write: Up to 46 MB/sec
- **Capacity**
 - 8, 16, 32, 64 GB
- **NAND Flash Type:** MLC
- **MTBF > 1,000,000 hours**
- **Temperature Range**
 - Operating:
 - Standard: 0°C to 70°C
 - Extended: -40°C to 85°C
 - Storage: -40°C to 100°C
- **Form Factor**
 - ATA Disk Module
 - Dimension: 49.39x27.10x6.00 (unit: mm)
- **Flash Management**
 - Advanced wear-leveling algorithms
 - Built-in Hardware ECC
 - Flash block management
 - Power failure management
- **ATA Secure Erase**
- **Shock & Vibration****
 - Shock: 1,500 G
 - Vibration: 15 G
- **RoHS Recast Compliant (2011/65/EU)**
- **S.M.A.R.T. Technology**
- **Master/Slave Switch (optional)**

*Performance and power consumption addressed here are typical and may vary from flash configurations or platforms.

**Non-operating

Table of Contents

1. General Description	3
1.1 Performance-Optimized Controller	3
1.1.1 Power Management.....	3
1.1.2 DATA Buffer.....	3
2. Functional Block	4
3. Pin Assignments.....	5
4. Product Specifications.....	6
4.1 Capacity.....	6
4.2 Performance	6
4.3 Environmental Specifications	6
5. Flash Management	7
5.1 Advanced Wear-Leveling Algorithms	7
5.2 Built-in Hardware ECC	7
5.3 Flash Block Management	7
5.4 Power Failure Management	7
6. Software Interface	8
7. Electrical Specifications.....	10
8. Mechanical Specifications	11
8.1 Without Housing	11
8.2 With Housing	11
9. Product Ordering Information.....	12
9.1 Product Code Designations.....	12
9.2 Valid Combinations.....	13
9.2.1 Middle Profile w/o Housing	13
9.2.2 Middle Profile w/ Housing	13
9.2.3 Middle Profile w/o Housing	13
9.2.4 Middle Profile w/ Housing	13

1. General Description

Apacer's ATA Disk Module 5S (ADM5S) SSD delivers ultra smooth performance and extremely low power consumption. This device supports DMA mode up to UDMA 6 that offers advanced data transfer technology and internal memory efficiency, which effectively decreases the loading for the microprocessor. Compliant with ATA/ATAPI-8 standards, our ADM5S supports data transfer modes up to PIO 4, Multiword DMA 2, and Ultra DMA 6. Equipped with power Error Correction Coding (ECC) up to 72bit/1KB, the ADM5S can provide high data integrity. Aside from data efficiency, the ADM5S also comes with power management. The device can work at 3.3V or 5V power supply, with the output voltage automatically adjusted by the voltage regulator in the core. In addition, the built-in ECC engine can support multi-mode correction capability up to 72 bits and perform effective decoding throughput with high reliability.

Well suited for embedded flash storage applications by offering new and expanded functionalities as well as more cost-effective designs, better performance and increased reliability, ADM is designed to work at either 5 or 3.3 Volts, and supports the standard ATA driver complying with all major operating systems such as Microsoft's Windows series, Apple's Mac OS family, and Unix variants. Featuring technologies as Advanced Wear-leveling algorithms, S.M.A.R.T, Intelligent Power Failure Recovery, and ATA Secure Erase, Apacer's ADM assures users of a versatile device on data storage.

1.1 Performance-Optimized Controller

The heart of an ATA-Disk Module is the ATA controller, which translates standard ATA signals into the data and controls of the flash media. This proprietary ATA controller is specifically designed to attain high data throughput from the host to the flash.

1.1.1 Power Management

The controller unit of this ADM storage device is made for power efficiency. It comes with built-in 2.7V voltage detectors for power fail prevention. In addition, it also supports 1.2V power-on reset.

1.1.2 DATA Buffer

The ATA-Disk Module Controller is programmed with a 128KB data buffer to optimize the host's data transfer to and from the flash media.

2. Functional Block

The ATA-Disk Module (ADM) includes the ATA controller and flash media, as well as the ATA standard interface. Figure 2-1 shows the functional block diagram.

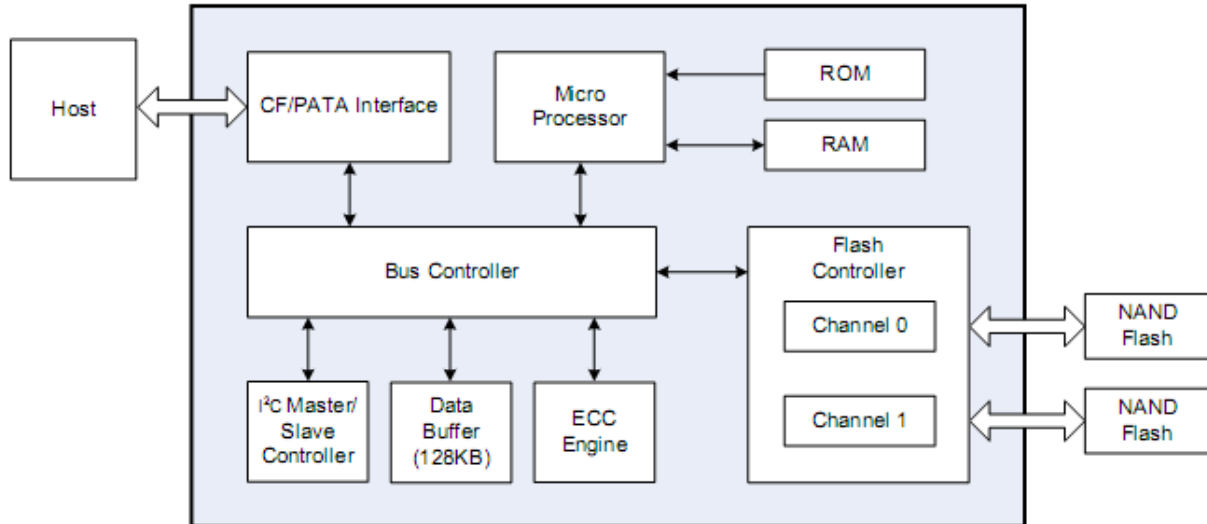

Figure 2-1: Functional Block Diagram

3. Pin Assignments

Table 3-1 lists the pin assignments with respective signal names for the 44-pin configuration. A “#” suffix indicates the active low signal. The pin type can be input, output or input/output.

Table 3-1: Pin Assignments for the 44-Pin Configuration

Pin No.	Signal Name	Pin Type	I/O Type*	Pin No.	Signal Name	Pin Type	I/O Type
1	RESET#	I	I2U	2	GND	-	Ground
3	D7	I/O	I1Z, O2	4	D8	I/O	I1Z, O2
5	D6	I/O	I1Z, O2	6	D9	I/O	I1Z, O2
7	D5	I/O	I1Z, O2	8	D10	I/O	I1Z, O2
9	D4	I/O	I1Z, O2	10	D11	I/O	I1Z, O2
11	D3	I/O	I1Z, O2	12	D12	I/O	I1Z, O2
13	D2	I/O	I1Z, O2	14	D13	I/O	I1Z, O2
15	D1	I/O	I1Z, O2	16	D14	I/O	I1Z, O2
17	D0	I/O	I1Z, O2	18	D15	I/O	I1Z, O2
19	GND	-	Ground	20	NC	-	-
21	DMARQ#	O	O1	22	GND	-	Ground
23	IOWR# STOP	I	I2Z	24	GND	-	Ground
25	IORD# HDMARDY# HSTROBE#	I	I2Z	26	GND	-	Ground
27	IORDY DDMARDY# DSTROBE	O	O1	28	NC/CSEL	I	I1U
29	DMACK#	I	I2U	30	NC/WP# ¹	-/I	-/I1U
31	INTRQ	O	O1	32	IOCS16#	O	O2
33	A1	I	I1Z	34	PDIAG#	I/O	I1U, O1
35	A0	I	I1Z	36	A2	I	I1Z
37	CS1FX#	I	I2Z	38	CS3FX#	I	I2Z
39	DASP#	I/O	I1U, O6	40	GND	-	Ground
41	VDD	-	Power	42	VDD	-	Power
43	GND	-	Ground	44	NC	-	-

*Pin 30 is selectable as NC or WP# through a zero ohm resistor jumper. Default is NC. Note that pin 30 is a GND pin on standard ATA interface. This pin could be redesigned for host to control the write protect function on ADM

4. Product Specifications

4.1 Capacity

Capacity specifications of the ATA-Disk Module (ADM) product family are available as shown in Table 4-1.

Table 4-1: Capacity Specifications (unformatted)

Capacity	Total bytes	Cylinders	Heads	Sectors	Max LBA
8 GB	8,012,390,400	15525	16	63	15,649,200
16 GB	16,013,942,784	16383	16	63	31,277,232
32 GB	32,017,047,552	16383	16	63	62,533,296
64 GB	64,023,257,088	16383	16	63	125,045,424

*Cylinders, heads or sectors are not applicable for these capacities. Only LBA addressing applies

**Notes: 1 GB = 1,000,000,000 bytes; 1 sector = 512 bytes.

LBA count addressed in the table above indicates total user storage capacity and will remain the same throughout the lifespan of the device. However, the total usable capacity of the SSD is most likely to be less than the total physical capacity because a small portion of the capacity is reserved for device maintenance usages.

4.2 Performance

Performance of the ATA-Disk Module is listed in Table 4-2.

Table 4-2: Performance Specifications

Capacity	8 GB	16 GB	32 GB	64 GB
Performance				
Sustained read (MB/s)	70	70	70	100
Sustained write (MB/s)	30	30	30	46

*Results may differ from various flash configurations and platforms.

4.3 Environmental Specifications

Environmental specifications of the ATA-Disk Module (ADM) follow the MIL-STD-810F standard.

Table 4-3: Environmental Specifications

Environment		Specifications
Temperature	Operating	0°C to 70°C (Standard); -40°C to 85°C (Extended)
	Storage	-40°C to 100°C
Vibration (Non-Operating)		Sine wave: 10~2000Hz, 15G (X, Y, Z axes)
Shock (Non-Operating)		Half sine wave, 1500 G, 11 ms (X, Y, Z ; All 6 axes)

5. Flash Management

5.1 Advanced Wear-Leveling Algorithms

Flash memory devices differ from Hard Disk Drives (HDDs) in terms of how blocks are utilized. For HDDs, when a change is made to stored data, like erase or update, the controller mechanism on HDDs will perform overwrites on blocks. Unlike HDDs, flash blocks cannot be overwritten and each P/E cycle wears down the lifespan of blocks gradually. Repeatedly program/erase cycles performed on the same memory cells will eventually cause some blocks to age faster than others. This would bring flash storages to their end of service term sooner. Wear leveling is an important mechanism that level out the wearing of blocks so that the wearing-down of blocks can be almost evenly distributed. This will increase the lifespan of SSDs. Commonly used wear leveling types are Static and Dynamic.

5.2 Built-in Hardware ECC

The properties of NAND flash memory make it ideal for applications that require high integrity while operating in challenging environments. The integrity of data to NAND flash memory is generally maintained through ECC algorithms. This ATA-Flash Drive is programmed with a hardware ECC engine which correct up to 72 bits per 1KB.

5.3 Flash Block Management

Current production technology is unable to guarantee total reliability of NAND flash memory array. When a flash memory device leaves factory, it comes with a minimal number of initial bad blocks during production or out-of-factory as there is no currently known technology that produce flash chips free of bad blocks. In addition, bad blocks may develop during program/erase cycles. When host performs program/erase command on a block, bad block may appear in Status Register. Since bad blocks are inevitable, the solution is to keep them in control. Apacer flash devices are programmed with ECC, block mapping technique and S.M.A.R.T to reduce invalidity or error. Once bad blocks are detected, data in those blocks will be transferred to free blocks and error will be corrected by designated algorithms.

5.4 Power Failure Management

Power Failure Management plays a crucial role when experiencing unstable power supply. Power disruption may occur when users are storing data into the SSD. In this urgent situation, the controller would run multiple write-to-flash cycles to store the metadata for later block rebuilding. This urgent operation requires about several milliseconds to get it done. At the next power up, the firmware will perform a status tracking to retrieve the mapping table and resume previously programmed NAND blocks to check if there is any incompleteness of transmission.

5.5 Mean Time Between Failures (MTBF)

Mean Time Between Failures (MTBF) is predicted based on reliability data for the individual components in the drive. The prediction result for the drive is more than 1,000,000 hours.

Notes about the MTBF:

The MTBF is predicated and calculated based on “Telcordia Technologies Special Report, SR-332, Issue 2” method.

6. Software Interface

6.1 Command Set

This section defines the software requirements and the format of the commands the host sends to the ATA-Disk Module (ADM). Commands are issued to the ADM by loading the required registers in the command block with the supplied parameters, and then writing the command code to the Command register. The manner in which a command is accepted varies.

Table 6-1: Command Set (1 of 2)

Command	Code
Check-Power-Mode	E5H or 98H
Execute-Drive-Diagnostic	90H
Erase Sector(s)	C0H
Flush-Cache	E7H
Format Track	50H
Identify-Drive	ECH
Idle	E3H or 97H
Idle-Immediate	E1H or 95H
Initialize-Drive-Parameters	91H
NOP	00H
Read-Buffer	E4H
Read-DMA	C8H or C9H
Read-Multiple	C4H
Read-Sector(s)	20H or 21H
Read-Verify-Sector(s)	40H or 41H
Recalibrate	1XH
Request-Sense	03H
Security-Disable-Password	F6H
Security-Erase-Prepare	F3H
Security-Erase-Unit	F4H
Security-Freeze-Lock	F5H
Security-Set-Password	F1H
Security-Unlock	F2H
Seek	7XH
Set-Features	EFH

Table 6-1: Command Set (2 of 2)

Command	Code
SMART	B0H
Set-Multiple-Mode	C6H
Set-Sleep-Mode	E6H or 99H
Standby	E2H or 96H
Standby-Immediate	E0H or 94H
Translate-Sector	87H
Write-Buffer	E8H
Write-DMA	CAH or CBH
Write-Multiple	C5H
Write-Multiple-Without-Erase	CDH
Write-Sector(s)	30H or 31H
Write-Sector-Without-Erase	38H
Write-Verify	3CH

6.2 S.M.A.R.T.

S.M.A.R.T. is an acronym for Self-Monitoring, Analysis and Reporting Technology, an open standard allowing disk drives to automatically monitor their own health and report potential problems. It protects the user from unscheduled downtime by monitoring and storing critical drive performance and attributes parameters. Ideally, this should allow taking proactive actions to prevent impending drive failure.

Apacer devices use the standard SMART command B0h to read data out from the drive to activate our SMART feature that complies with the ATA/ATAPI-7 specifications. Based on the SFF-8035i Rev. 2.0 specifications, SMART Attribute IDs shall include Initial bad block count, Bad block count, Spare block count, Maximum erase count, Average erase count and Power cycle. When the SMART Utility running on the host, it analyzes and reports the disk status to the host before the device reaches in critical condition.

6.3. ATA Secure Erase

ATA Secure Erase is an ATA disk purging command currently embedded in most of the storage drives. Defined in ATA specifications, (ATA) Secure Erase is part of Security Feature Set that allows storage drives to erase all user data areas. The erase process usually runs on the firmware level as most of the ATA-based storage media currently in the market are built-in with this command. ATA Secure Erase can securely wipe out the user data in the drive and protects it from malicious attack.

7. Electrical Specifications

Table 7-1: Operating Range

Ambient Temperature	0°C to 70°C
Extended Temperature	-40°C to 85°C
Operating Voltage	3.3V ± 5% (3.135-3.465V) 5V ± 5% (4.75-5.25V)

Table 7-2: Power Consumption (typical)

Capacity	8 GB	16 GB	32 GB	64 GB
Modes				
Active (mA)	210	210	210	250
Idle (mA)	10	10	10	170

*Results were tested at 5.0V power supply and may differ from various flash configurations and platforms.

8. Mechanical Specifications

8.1 Without Housing



8.2 With Housing

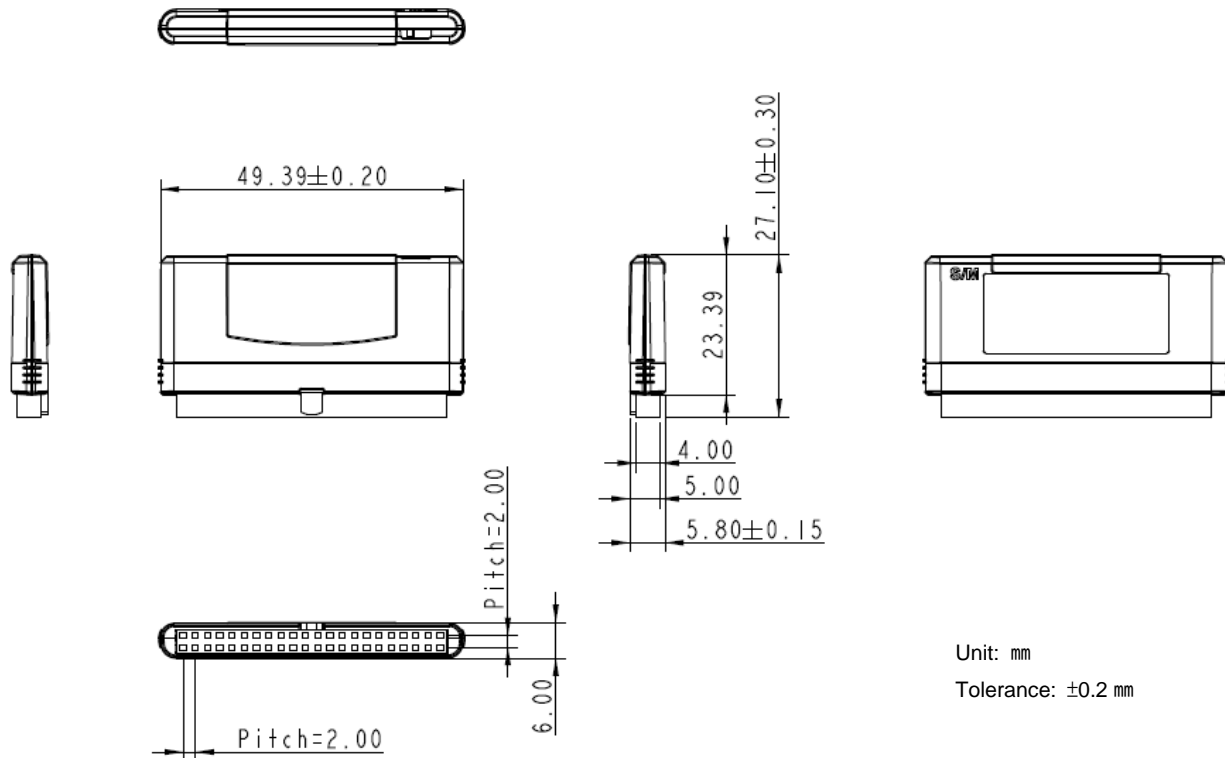

9. Product Ordering Information

9.1 Product Code Designations

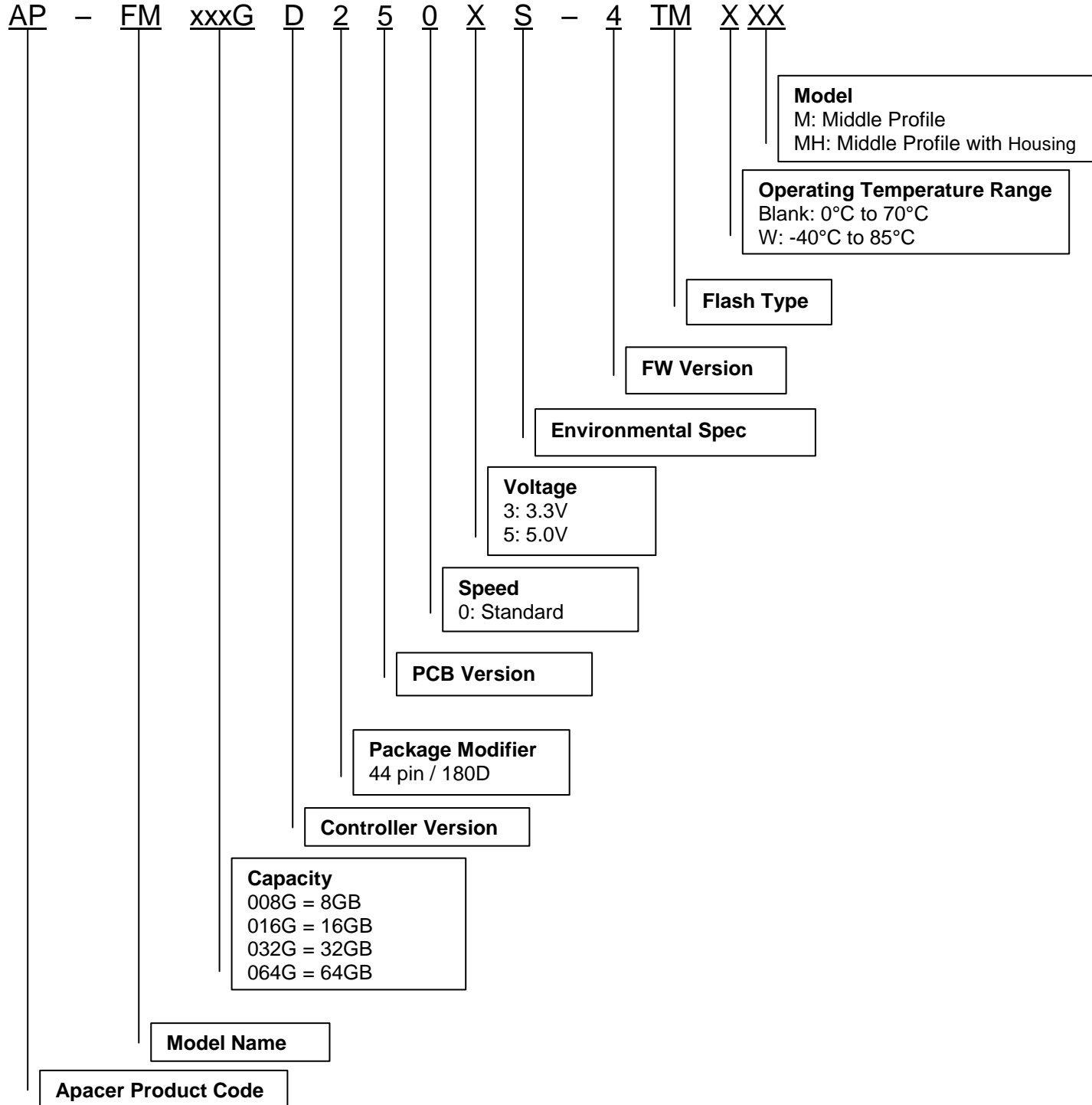

9.2 Valid Combinations

A. Standard Temperature

9.2.1 Middle Profile w/o Housing

Capacity	P/N (3.3V)	P/N (5V)
8GB	AP-FM008GD2503S-4TMM	AP-FM008GD2505S-4TMM
16GB	AP-FM016GD2503S-4TMM	AP-FM016GD2505S-4TMM
32GB	AP-FM032GD2503S-4TMM	AP-FM032GD2505S-4TMM
64GB	AP-FM064GD2503S-4TMM	AP-FM064GD2505S-4TMM

9.2.2 Middle Profile w/ Housing

Capacity	P/N (3.3V)	P/N (5V)
8GB	AP-FM008GD2503S-4TMMH	AP-FM008GD2505S-4TMMH
16GB	AP-FM016GD2503S-4TMMH	AP-FM016GD2505S-4TMMH
32GB	AP-FM032GD2503S-4TMMH	AP-FM032GD2505S-4TMMH
64GB	AP-FM064GD2503S-4TMMH	AP-FM064GD2505S-4TMMH

B. Extended Temperature

9.2.3 Middle Profile w/o Housing

Capacity	P/N (3.3V)	P/N (5V)
8GB	AP-FM008GD2503S-4TMWM	AP-FM008GD2505S-4TMWM
16GB	AP-FM016GD2503S-4TMWM	AP-FM016GD2505S-4TMWM
32GB	AP-FM032GD2503S-4TMWM	AP-FM032GD2505S-4TMWM
64GB	AP-FM064GD2503S-4TMWM	AP-FM064GD2505S-4TMWM

9.2.4 Middle Profile w/ Housing

Capacity	P/N (3.3V)	P/N (5V)
8GB	AP-FM008GD2503S-4TMWMH	AP-FM008GD2505S-4TMWMH
16GB	AP-FM016GD2503S-4TMWMH	AP-FM016GD2505S-4TMWMH
32GB	AP-FM032GD2503S-4TMWMH	AP-FM032GD2505S-4TMWMH
64GB	AP-FM064GD2503S-4TMWMH	AP-FM064GD2505S-4TMWMH

Note: Valid combinations are those products in mass production or will be in mass production. Consult your Apacer sales representative to confirm availability of valid combinations and to determine availability of new combinations.

Revision History

Revision	Date	Description	Remark
1.0	1/11/2016	Official release	

Global Presence

Taiwan (Headquarters)	Apacer Technology Inc. 1F., No.32, Zhongcheng Rd., Tucheng Dist., New Taipei City 236, Taiwan R.O.C. Tel: 886-2-2267-8000 Fax: 886-2-2267-2261 amtsales@apacer.com
U.S.A.	Apacer Memory America, Inc. 46732 Lakeview Blvd., Fremont, CA 94538 Tel: 1-408-518-8699 Fax: 1-510-249-9568 sa@apacerus.com
Japan	Apacer Technology Corp. 5F, Matsura Bldg., Shiba, Minato-Ku Tokyo, 105-0014, Japan Tel: 81-3-5419-2668 Fax: 81-3-5419-0018 jpservices@apacer.com
Europe	Apacer Technology B.V. Science Park Eindhoven 5051 5692 EB Son, The Netherlands Tel: 31-40-267-0000 Fax: 31-40-267-0000#6199 sales@apacer.nl
China	Apacer Electronic (Shanghai) Co., Ltd Room D, 22/FL, No.2, Lane 600, JieyunPlaza, Tianshan RD, Shanghai, 200051, China Tel: 86-21-6228-9939 Fax: 86-21-6228-9936 sales@apacer.com.cn
India	Apacer Technologies Pvt Ltd, Unit No.201, "Brigade Corner", 7 th Block Jayanagar, Yediyur Circle, Bangalore – 560082, India Tel: 91-80-4152-9061 Fax: 91-80-4170-0215 sales_india@apacer.com